

NOTES:

1. MATERIAL:
 - 1.1 HOUSING: THERMOPLASTIC, HIGH TEMP.,UL94V-0;
 - 1.2 CONTACT: COPPER ALLOY
 - 1.3 FITTING NAIL: COPPER ALLOY
 - 1.4 LATCH: THERMOPLASTIC, HIGH TEMP.,UL94V-0;
2. FINISH:
 - 2.1 CONTACT AREA:
 - 1: 50u"MIN. NICKEL UNDERPLATING OVERALL.
 - GOLD FLASH PLATING
 - 2.2 SOLDER AREA:
 - 1: 50u"MIN. NICKEL UNDERPLATING OVERALL.
 - GOLD FLASH PLATING
 - 2.3 FITTING NAIL:
 - N: 50u"MIN. NICKEL UNDERPLATING OVERALL.
 - 120u"MIN. MATTE TIN PLATING
3. REFLOW SOLDER CAPABLE TO 260°C PER ACES SPEC.
4. SPEC. PLS. REFER TO PS-51696-XXXXX-XXX
5. PACKAGE PLS. REFER TO 51696-XXXXX-XX-TRP
6. PART NO.

51696-XXX X X-PXX	XXX	Housing Color	Actuator Color
NO OF CKT	P01	WHITE	BLACK
PACKING	PLATING		
0: TAPE & REEL	1: GOLD FLASH		

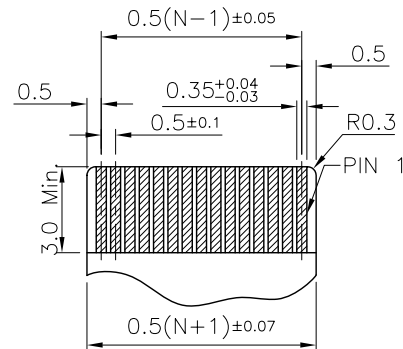

RECOMMENDED APPLICABLE FPC LAYOUT
GENERAL TOLERANCE ±0.05
(THICKNESS: 0.3±0.03)

CKT	DIM A	DIM B	DIM C	DIM D
12	5.5	11.8	12.9	6.65

一般公差 TOLERANCES X ±0.5 .XX ±0.15 X ±0.25 .XXX ±0.1 ANGLES ±2°	宏致電子股份有限公司 Aces Electronics Co.,Ltd.	
檢驗尺寸標示 SYMBOLS ⊕ INDICATE CLASSIFICATION DIMENSION ⊕ MARK IS CRITICAL DIM. ⊕ MARK IS MAJOR DIM.	品名 (TITLE) 0.5 mm ZIF FPC CONN. SMT S/T TYPE	製圖 (DR) XUBIN 16/07/27 審核 (CHKD) BRAVE
	圖號 (DWG NO.) 51696-XXXXX-PXX (COMPAL)	核准 (APPD) FRANK
表面處理 (FINISH)	比例 (SCALE) 4:1 單位 (UNITS) mm	張數 (SHEET) 1 OF 1 SIZE A4 REV 0